



TecNiq's New Surface Mounted Interior Light

Whether for aesthetics or structural reasons, cutting a large hole to install an interior lamp inside a vessel, vehicle or trailer is often not an option. When a smooth, finished look is desired, TecNiq's E32 Surface Mounted Interior Light delivers a massive 2,200 lumens, yet has a profile of less than 3/4".

The E32 is offered in three models: standard, with a built-in manual on/off switch or with an integrated automatic motion detector switch. All are 14" L x 3.5" W and come with TecNiq's lifetime guarantee.

- Easy to install – Just need a 1/4" hole for the wire feed, and four screws
- Lens/Cover snaps on securely – giving a great looking light, no visible fasteners
- Available in three models – Standard, ON/OFF Button or Motion Detector Model for Auto ON/OFF function
- Light base is powder coated white for excellent corrosion resistance
- Massive amount of lumens for a 14" light – 2200 lumens. This is huge compared to other similar solutions on the market

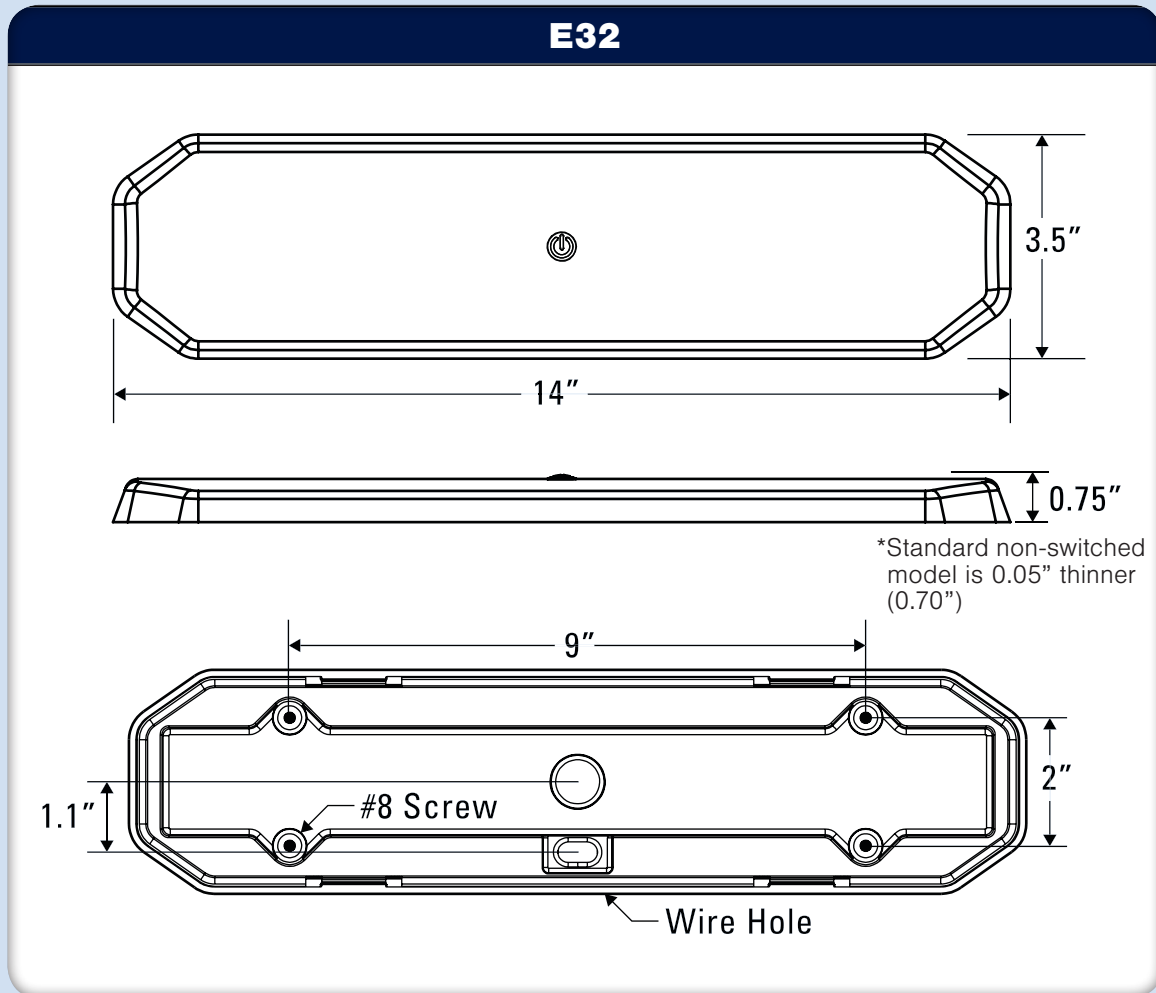

Part Number	Description	Amp Draw	Lumens	Connector
E32-L000-1	Interior 4K White 42 LED Surface Mount Light	1.36A - 1.84A	2200	12" Sheathed Pigtail
E32-L00S-1	Interior 4K White 42 LED Surface Mount Light W/ Switch			
E32-L00M-1	Interior 4K White 42 LED Surface Mount Light W/ Motion Detector			

Easy to install, the E32 requires a 1/4" hole and installs with four screws. The lens snaps on securely to the powder coated, corrosion-resistant base, while hiding all fasteners. It comes hard-wired with a 12" sheathed lead for fast, simple connection.